



Your Name: _____

Best Contact Phone Number: _____

Bike Info: Year _____ Make _____ Model _____

SYMPTOMS:

- Doesn't crank or doesn't start
- Idle is rough
- Idle is too high
- Engine hesitates or stumbles
- Engine pings or knocks
- Engine backfires (popping noise)
- Engine runs on after key is turned off
- Oil consumption, 1 qt every _____ miles
- Engine smokes
- Noise
- Other - Please fill out comment section below

HOW OFTEN DOES IT OCCUR?

- Always
- Sometimes
- Rarely
- Ever since the vehicle was new
- The problem just started

OTHER INFORMATION:

- Are you the original owner? **Y or N**
- Has the vehicle ever been in an accident? **Y or N**
- Has the vehicle been service recently? **Y or N**
- Where was your last service performed? _____
- Do you have an extended warranty? **Y or N**
- Do you have crash bars on your bike? **Y or N**
- Do you have aftermarket lighting? **Y or N**
- Age of your battery, if known? _____
- Note: If possible, please remove your bags prior to your service.

WHEN DOES IT OCCUR?

- Engine cold
- During engine warm-up
- Normal operating temperature
- Engine temperature very high
- All the time
- Other, explain: _____

- Only on hot days
- Only on cool or cold days
- Only on humid or rainy days
- Under hard acceleration
- Under medium acceleration
- Under light acceleration
- Under deceleration
- Under cruising - steady speeds
- At what MPH _____ RPM _____

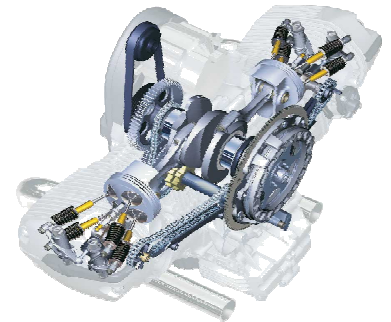

Please provide us with any additional information or comments that might help us in diagnosing your problem:

Comments: